

ÜIEF

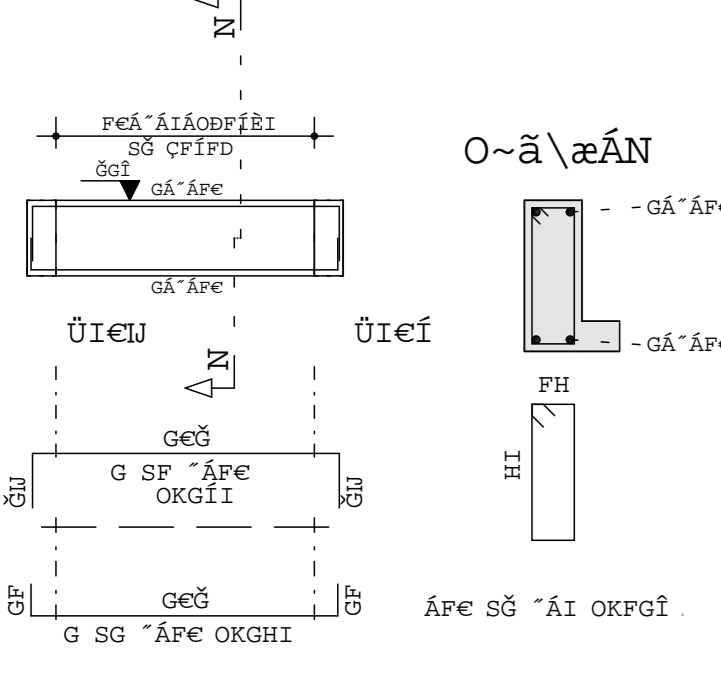

ÜIEĜ

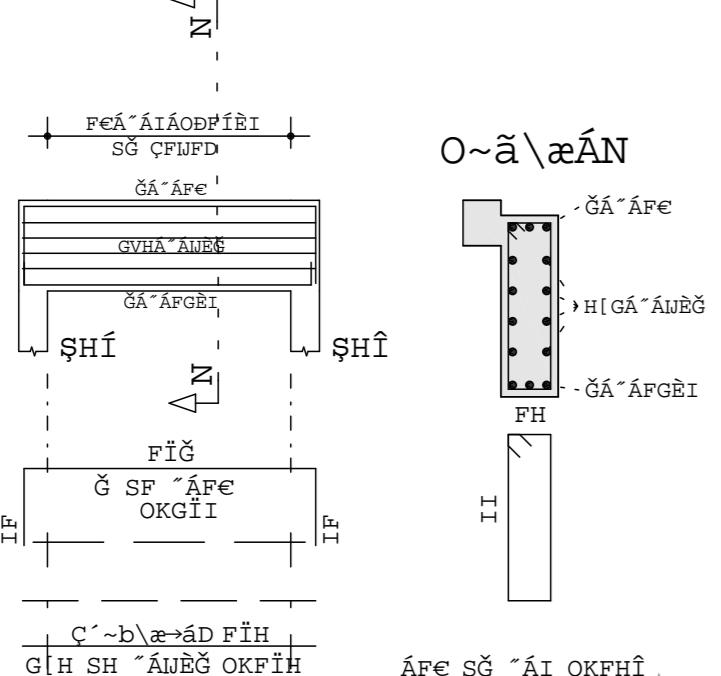

ÜIEĜ

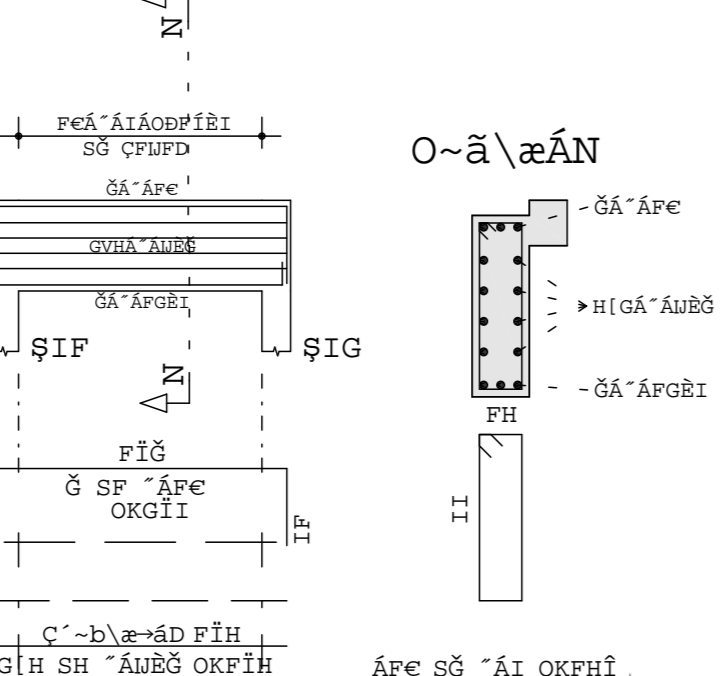

ÜIEH

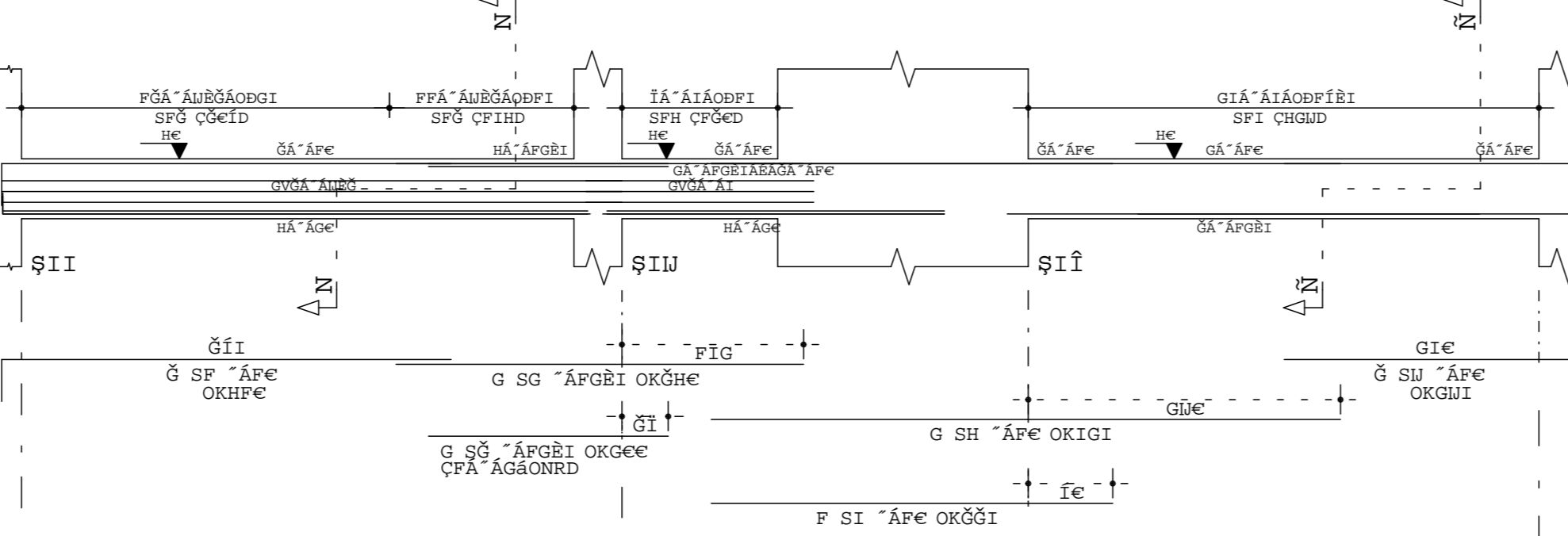

ÜIEI

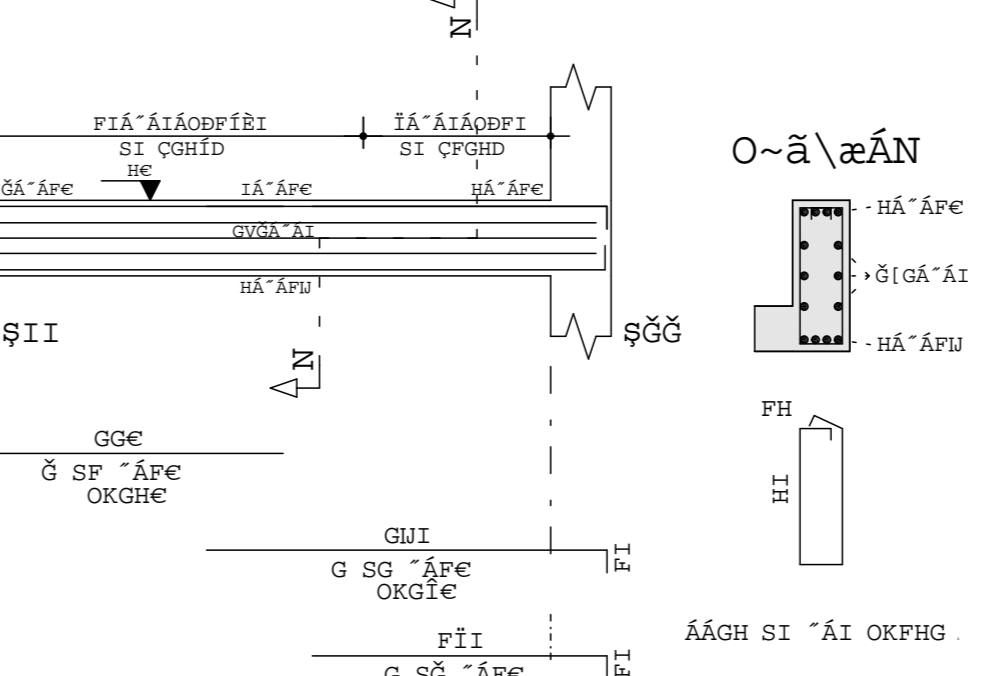

ÜIEÎ

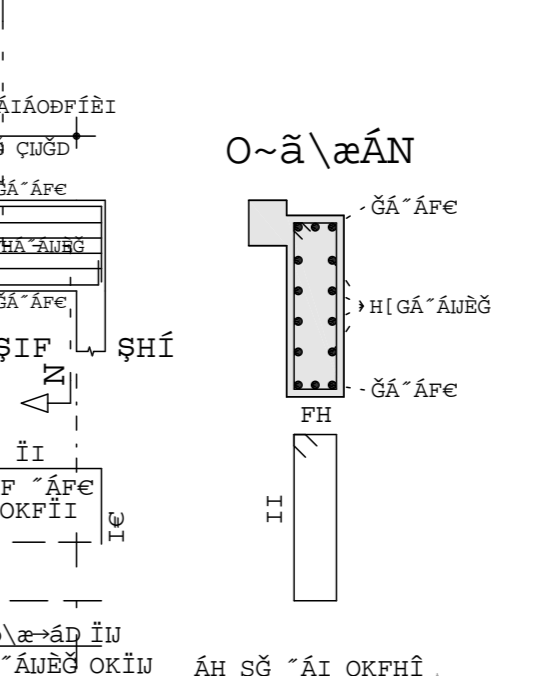

ÜIEÏ

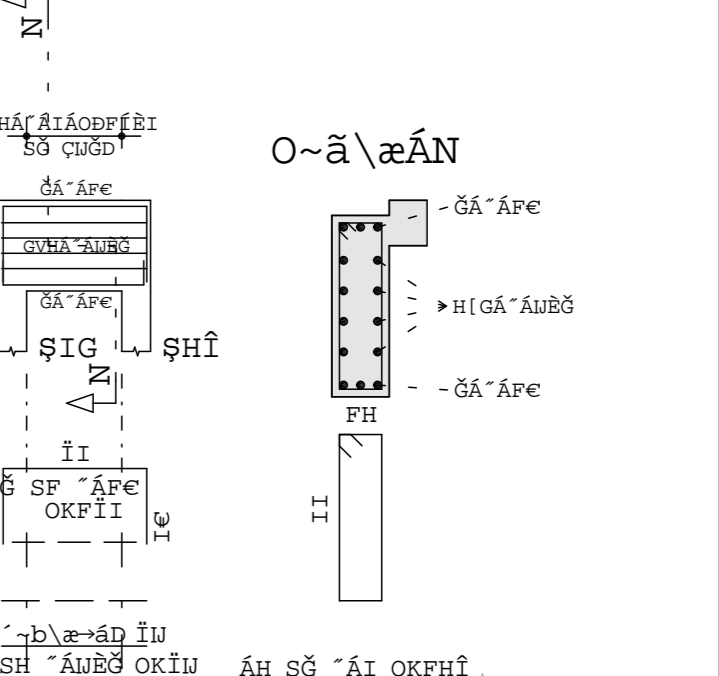

ÜIFE

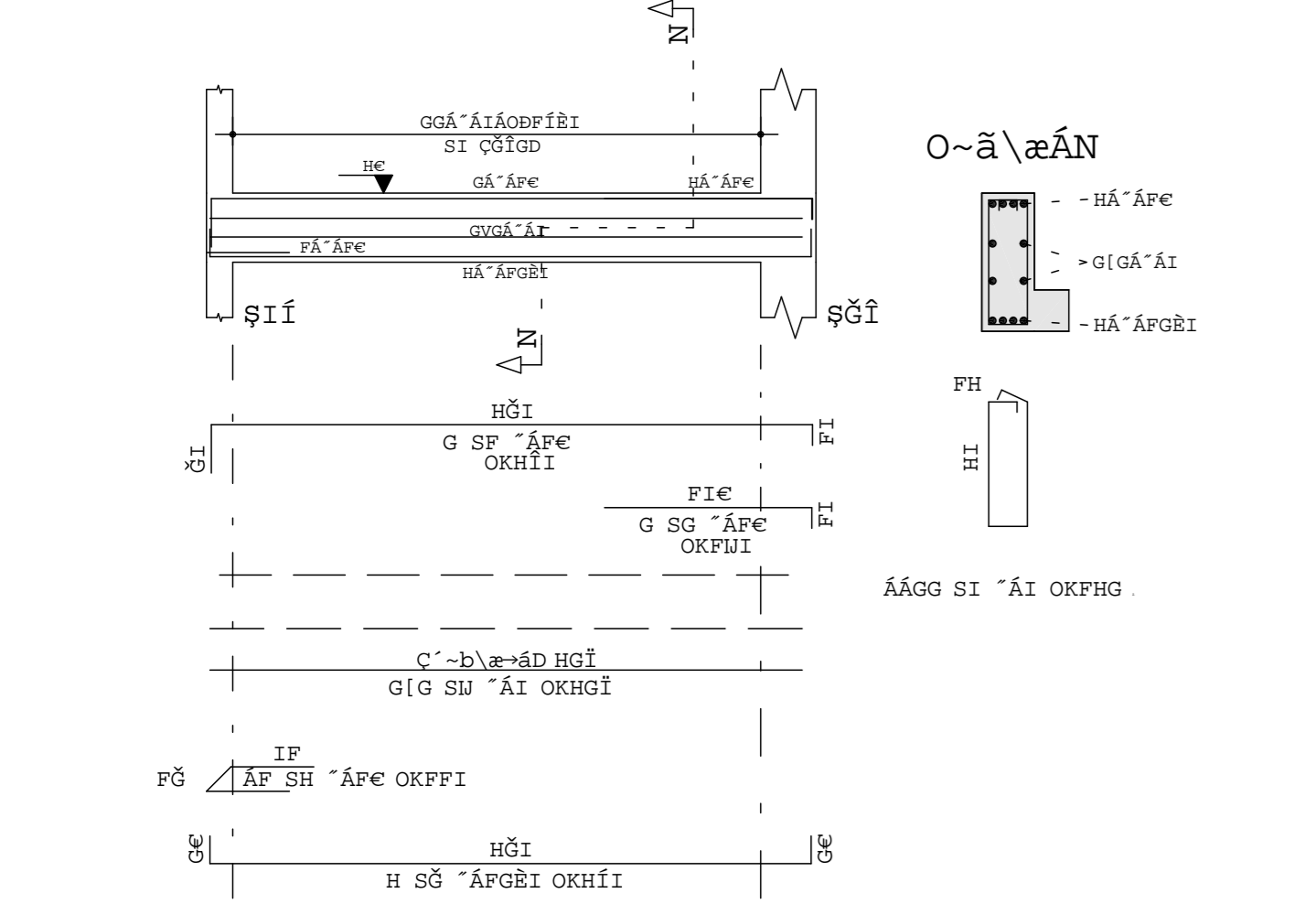

ÜIEU

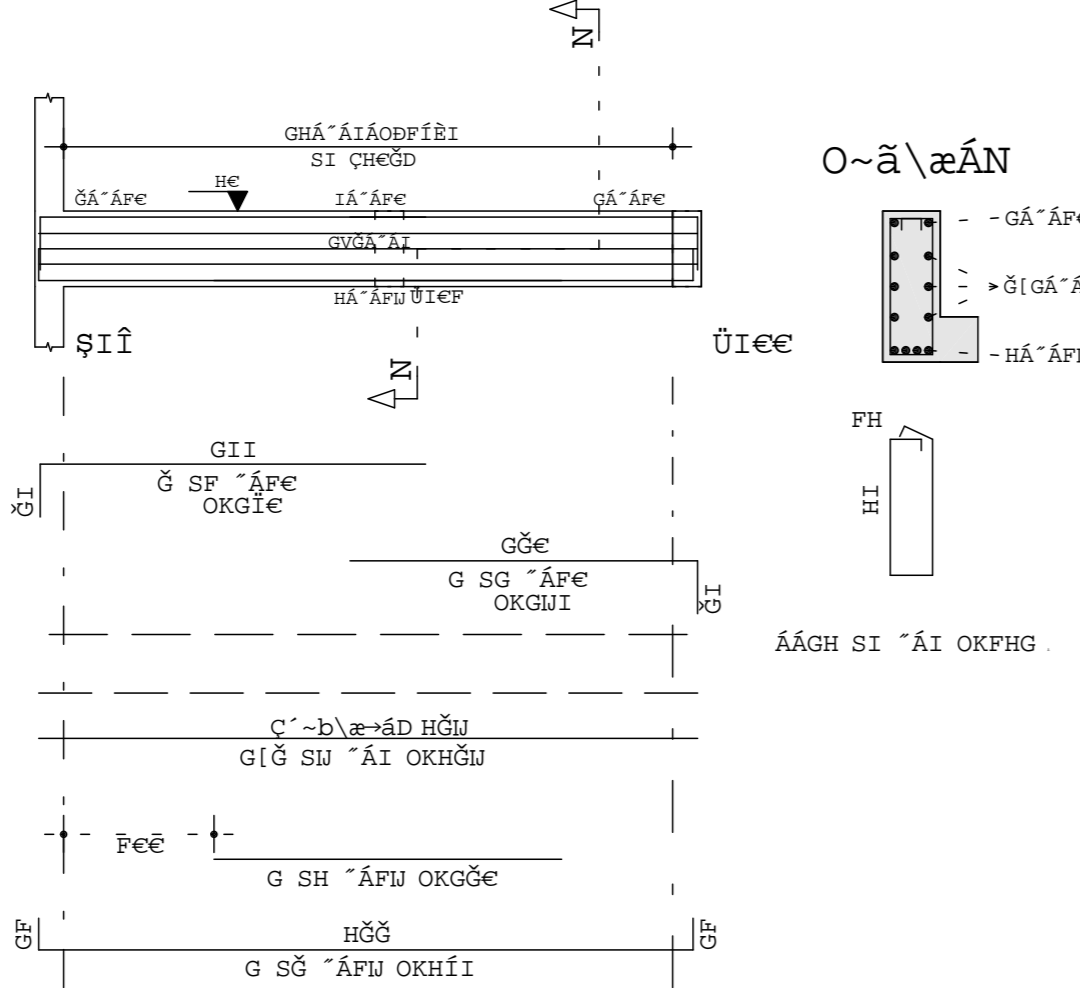

ÜIEE

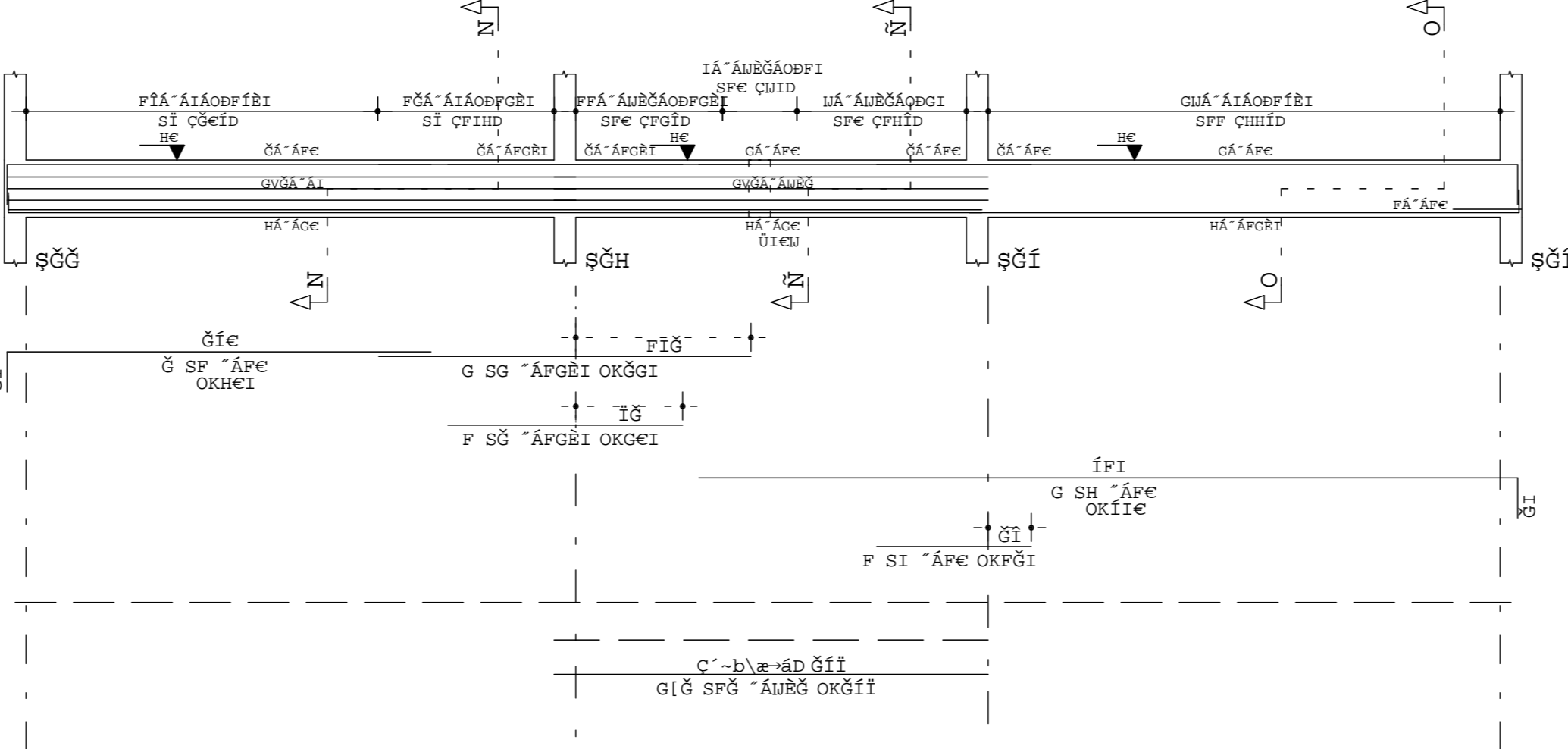

ÜIEİ

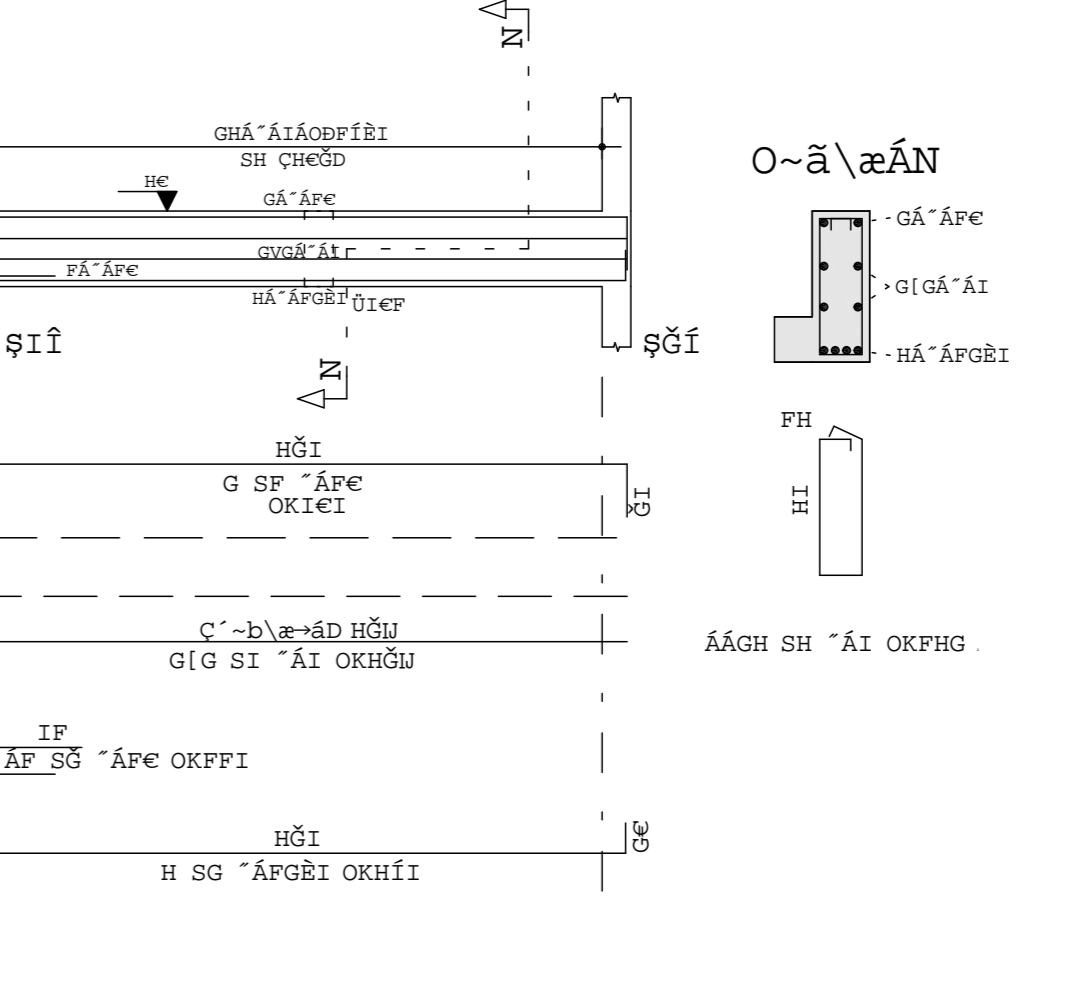

Table with columns: NeS, ŞŞU, NÖU, TÜNSÜ, ÖSRŞPŞORŞÖŞÜS, ÜSÜGÜ, ÜŞÜNGÜ, ÜŞÜNGÜ. Rows include ÜIEE, ÜIEF, ÜIEĜ, ÜIEH, ÜIEI, ÜIEU, ÜIEİ, ÜIEÏ, ÜIFE, ÜIEU, ÜIEE, ÜIEİ, ÜIEÏ, ÜIFE.

Table with columns: NeS, ŞŞU, NÖU, TÜNSÜ, ÖSRŞPŞORŞÖŞÜS, ÜSÜGÜ, ÜŞÜNGÜ, ÜŞÜNGÜ. Rows include ÜIEE, ÜIEF, ÜIEĜ, ÜIEH, ÜIEI, ÜIEU, ÜIEİ, ÜIEÏ, ÜIFE.

Table with columns: NeS, ŞŞU, NÖU, TÜNSÜ, ÖSRŞPŞORŞÖŞÜS, ÜSÜGÜ, ÜŞÜNGÜ, ÜŞÜNGÜ. Rows include ÜIEE, ÜIEF, ÜIEĜ, ÜIEH, ÜIEI, ÜIEU, ÜIEİ, ÜIEÏ, ÜIFE.

Complex block containing a logo, text in various languages (including English and German), and a grid with letters and symbols.